

### • General Description

The ZMC88601S combines advanced trench MOSFET technology with a low resistance package to provide extremely low  $R_{DS(ON)}$ . It combine one N Channel MOSFET and one P channel MOSFET.

### • Features

- Advance high cell density Trench technology
- Low  $R_{DS(ON)}$  to minimize conductive loss
- Low Gate Charge for fast switching
- Dual DIE in one package

### • Application

- Power Management in Notebook Computer
- BLDC Motor driver

### • Ordering Information:

Part NO.	ZMC88601S
Marking	ZMC88601
Packing Information	REEL TAPE
Basic ordering unit (pcs)	4000

### • N Channel Absolute Maximum Ratings ( $T_c = 25^\circ\text{C}$ )

Parameter	Symbol	Rating	Unit
Drain-Source Voltage	$V_{DS}$	60	V
Gate-Source Voltage	$V_{GS}$	$\pm 20$	V
Continuous Drain Current <sup>②</sup>	$I_D$	4.5	A
Pulsed Drain Current <sup>①</sup>	$I_{DM}$	13	A
Total Power Dissipation <sup>②</sup>	$P_D@TC=25^\circ\text{C}$	3.4	W
Total Power Dissipation	$P_D@TA=25^\circ\text{C}$	0.69	W
Operating Junction Temperature	$T_J$	-55 to 150	$^\circ\text{C}$
Storage Temperature	$T_{STG}$	-55 to 150	$^\circ\text{C}$

### • Product Summary

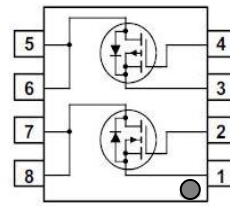

$V_{DS1} = 60\text{V}$   
 $V_{DS2} = -60\text{V}$   
 $R_{DS(ON)1} = 43\text{m}\Omega$   
 $R_{DS(ON)2} = 57\text{m}\Omega$   
 $I_{D1} = 4.5\text{A}$   
 $I_{D2} = -4.0\text{A}$

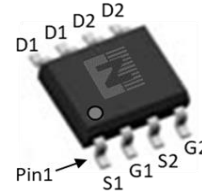

SOP8

**•P Channel Absolute Maximum Ratings (T<sub>c</sub> =25°C)**

Parameter	Symbol	Rating	Unit
Drain-Source Voltage	V <sub>DS</sub>	-60	V
Gate-Source Voltage	V <sub>GS</sub>	±20	V
Continuous Drain Current(TC=25°C)	I <sub>D</sub>	-4.0	A
Pulsed Drain Current <sup>①</sup>	I <sub>DM</sub>	-12	A
Total Power Dissipation <sup>②</sup>	P <sub>D</sub> @TC=25°C	3.6	W
Total Power Dissipation	P <sub>D</sub> @TA=25°C	0.69	W
Operating Junction Temperature	T <sub>J</sub>	-55 to 150	°C
Storage Temperature	T <sub>STG</sub>	-55 to 150	°C

**•Thermal resistance**

Parameter	Symbol	Min.	Typ.	Max.	Unit
Thermal resistance, junction - case	R <sub>thJC</sub>	-	-	56	° C/W
Thermal resistance, junction - ambient	R <sub>thJA</sub>	-	-	180	° C/W
Soldering temperature, wavesoldering for 10s	T <sub>sold</sub>	-	-	265	° C

**•N Channel Electronic Characteristics**

Parameter	Symbol	Condition	Min.	Typ	Max.	Unit
Drain-Source Breakdown Voltage	BV <sub>DSS</sub>	V <sub>GS</sub> =0V, I <sub>D</sub> =250uA	60			V
Gate Threshold Voltage	V <sub>GS(TH)</sub>	V <sub>GS</sub> =V <sub>DS</sub> , I <sub>D</sub> =250uA	1.2		2.5	V
Drain-Source Leakage Current	I <sub>DSS</sub>	V <sub>DS</sub> =60V, V <sub>GS</sub> =0V			1.0	uA
Gate- Source Leakage Current	I <sub>GSS</sub>	V <sub>GS</sub> =±20V ,V <sub>DS</sub> =0V			±100	nA
Static Drain-source On Resistance	R <sub>DS(ON)</sub>	V <sub>GS</sub> =10V, I <sub>D</sub> =4A		43	50	mΩ
		V <sub>GS</sub> =4.5V, I <sub>D</sub> =3A		75	85	mΩ
Forward Transconductance	g <sub>FS</sub>	V <sub>DS</sub> =10V, I <sub>D</sub> =4A		10		s
Diode Forward Voltage	V <sub>FSD</sub>	I <sub>SD</sub> =4A			1.28	V

**•Electronic Characteristics**

Parameter	Symbol	Condition	Min.	Typ	Max.	Unit
Input capacitance	C <sub>iss</sub>	V <sub>DS</sub> =25V f = 1MHz	-	1050	-	pF
Output capacitance	C <sub>oss</sub>		-	255	-	
Reverse transfer capacitance	C <sub>rss</sub>		-	185	-	

**•Gate Charge characteristics( $T_a = 25^\circ\text{C}$ )**

Parameter	Symbol	Condition	Min.	Typ	Max.	Unit
Total gate charge	Qg	VDD =25V	-	12	-	nC
Gate - Source charge	Qgs	ID = 4A	-	5	-	
Gate - Drain charge	Qgd	VGS = 10V	-	4	-	

**•P Channel Electronic Characteristics**

Parameter	Symbol	Condition	Min.	Typ	Max.	Unit
Drain-Source Breakdown Voltage	BV <sub>DSS</sub>	V <sub>GS</sub> =0V, I <sub>D</sub> =-250uA	-60			V
Gate Threshold Voltage	V <sub>GS(TH)</sub>	V <sub>GS</sub> =V <sub>DS</sub> , I <sub>D</sub> =-250uA	-1.0		-2.5	V
Drain-Source Leakage Current	I <sub>DSS</sub>	V <sub>DS</sub> =-60V, V <sub>GS</sub> =0V			-1.0	uA
Gate- Source Leakage Current	I <sub>GSS</sub>	V <sub>GS</sub> =±20V ,V <sub>DS</sub> =0V			±100	nA
Static Drain-source On Resistance	R <sub>DS(ON)</sub>	V <sub>GS</sub> =-10V, I <sub>D</sub> =-4A		57	74	mΩ
		V <sub>GS</sub> =-4.5V, I <sub>D</sub> =-3A		76	100	mΩ
Forward Transconductance	g <sub>FS</sub>	V <sub>DS</sub> =-10V, I <sub>D</sub> =-3A		9		s
Diode Forward Voltage	V <sub>FSD</sub>	I <sub>SD</sub> =-4A			-1.28	V

**•Electronic Characteristics**

Parameter	Symbol	Condition	Min.	Typ	Max.	Unit
Input capacitance	C <sub>iss</sub>	V <sub>DS</sub> =25V f = 1MHz	-	1550	-	pF
Output capacitance	C <sub>oss</sub>		-	160	-	
Reverse transfer capacitance	C <sub>rss</sub>		-	140	-	

**•Gate Charge characteristics( $T_a = 25^\circ\text{C}$ )**

Parameter	Symbol	Condition	Min.	Typ	Max.	Unit
Total gate charge	Qg	VDD = -25V	-	23	-	nC
Gate - Source charge	Qgs	ID = -4A	-	4	-	
Gate - Drain charge	Qgd	VGS = -10V	-	9	-	

•N Channel characteristics curve

Fig.1 Power Dissipation Derating Curve

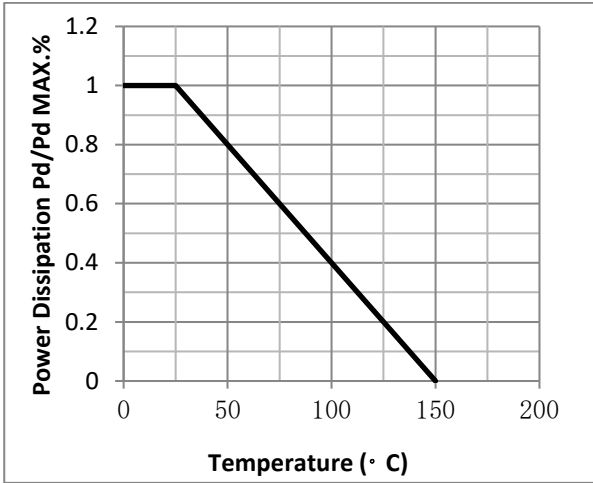

Fig.2 Typical output Characteristics

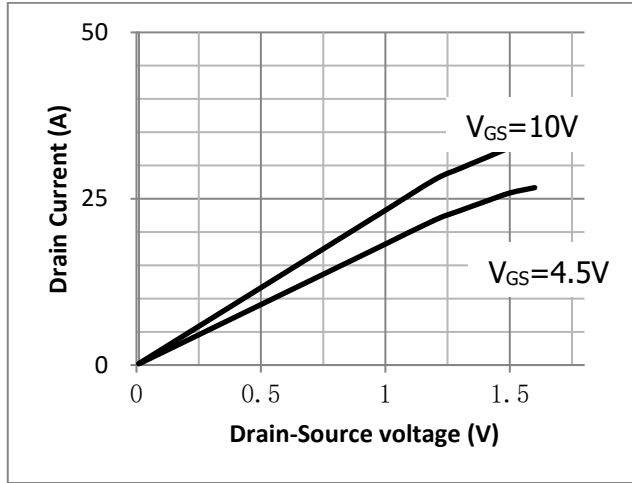

Fig.3 Threshold Voltage V.S Junction Temperature

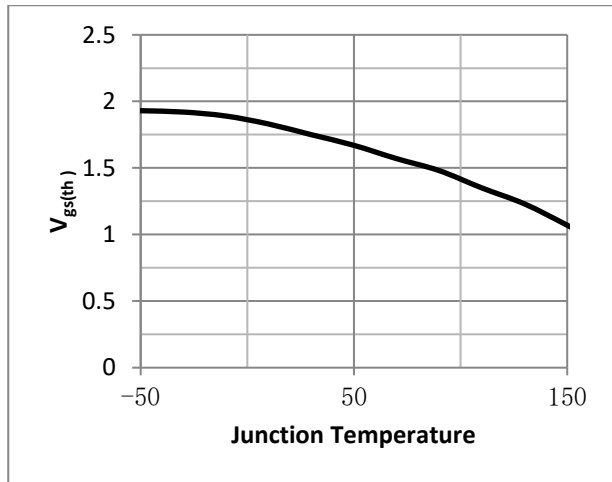

Fig.4 Resistance V.S Drain Current

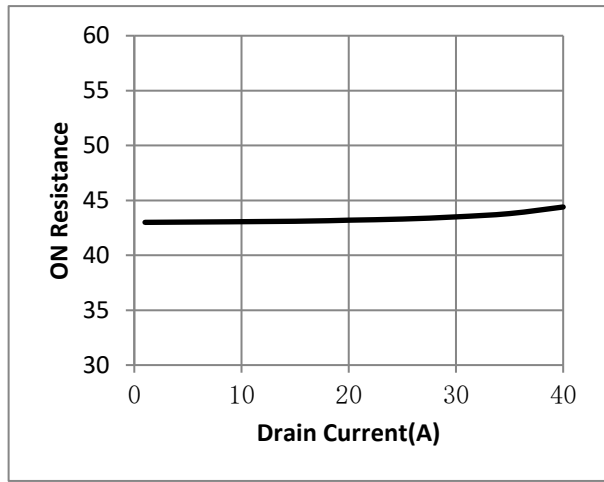

Fig.5 On-Resistance VS Gate Source Voltage

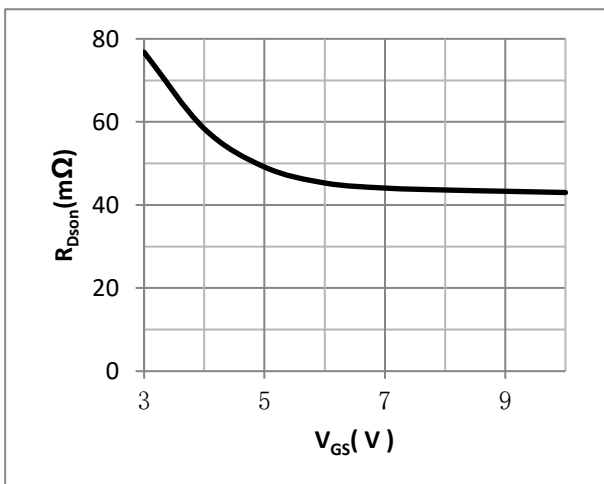
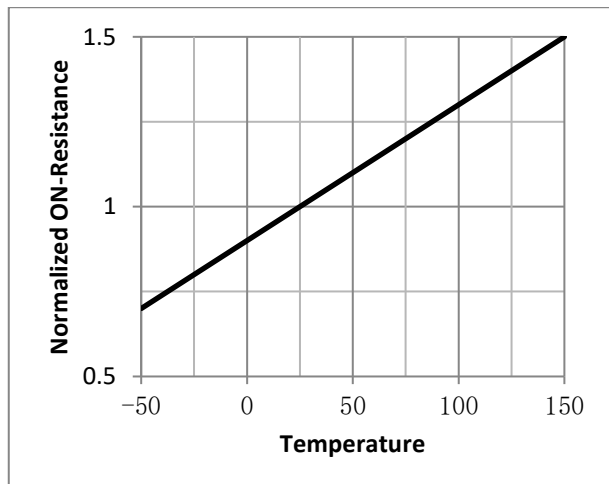

Fig.6 On-Resistance V.S Junction Temperature



•P Channel characteristics curve

Fig.1 Power Dissipation Derating Curve

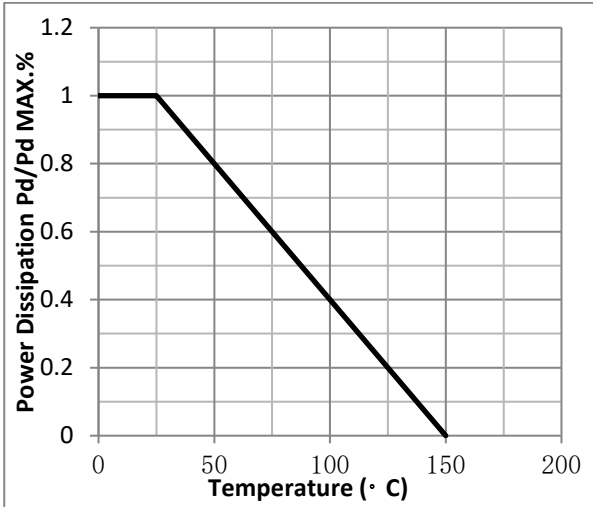

Fig.2 Typical output Characteristics

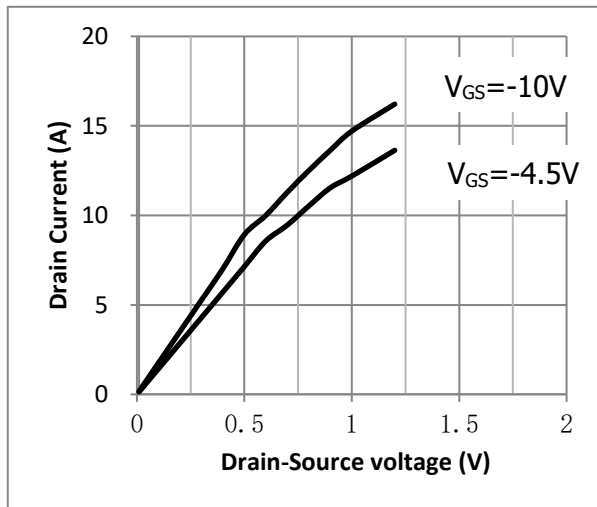

Fig.3 Threshold Voltage V.S Junction Temperature

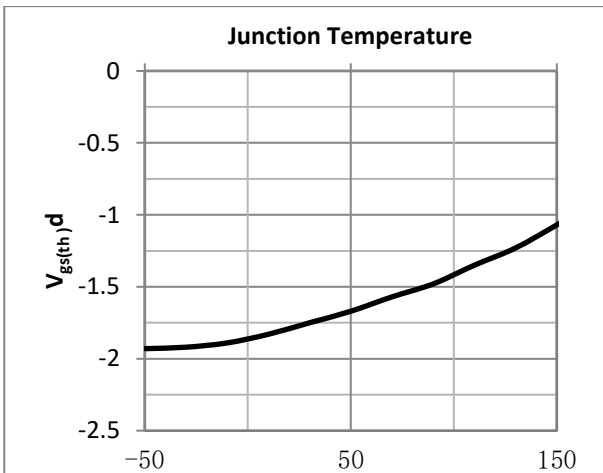

Fig.4 Resistance V.S Drain Current

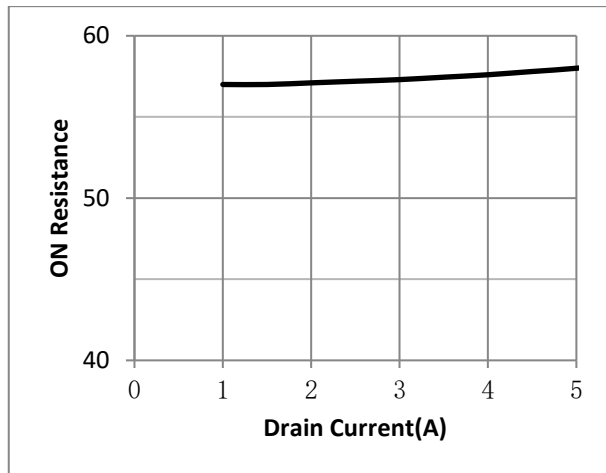

Fig.5 On-Resistance VS Gate Source Voltage

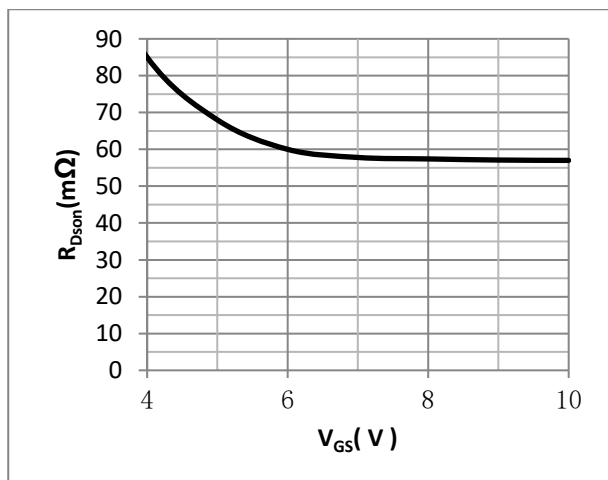
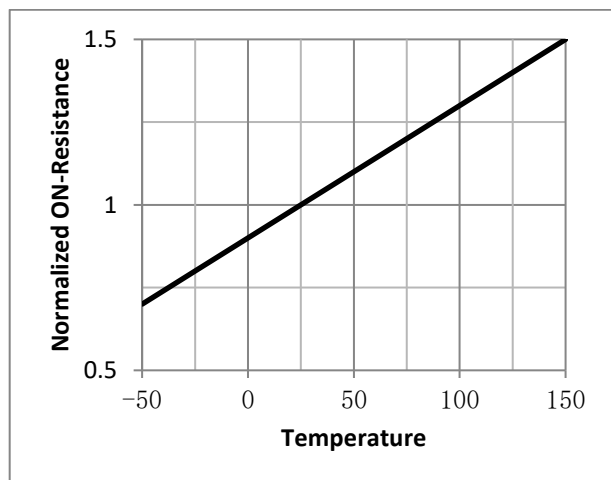

Fig.6 On-Resistance V.S Junction Temperature



•Test Circuit

Fig.1 Gate Charge Measurement Circuit

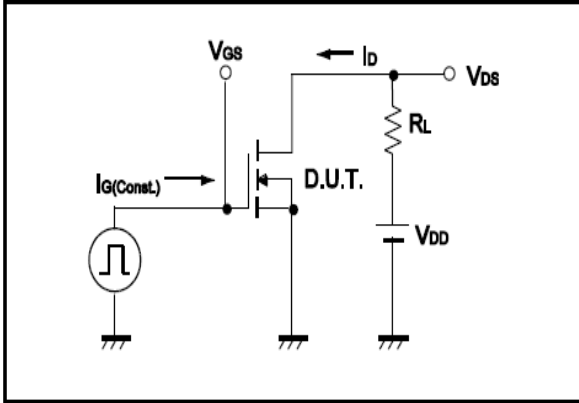

Fig.2 Gate Charge Waveform

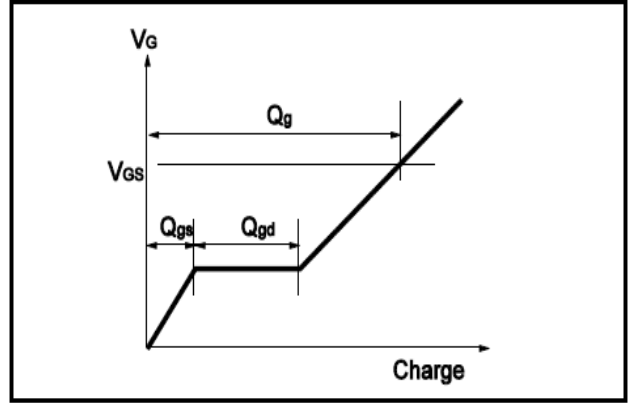

Fig.3 Switching Time Measurement Circuit

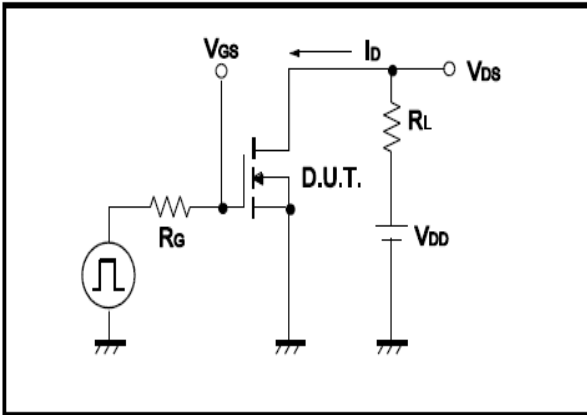

Fig.4 Switching Time Waveform

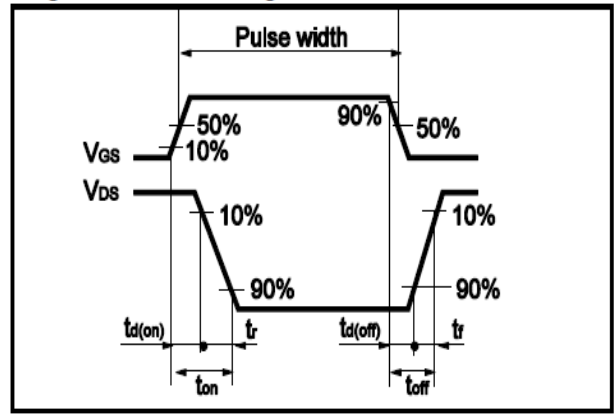

Fig.5 Avalanche Measurement Circuit

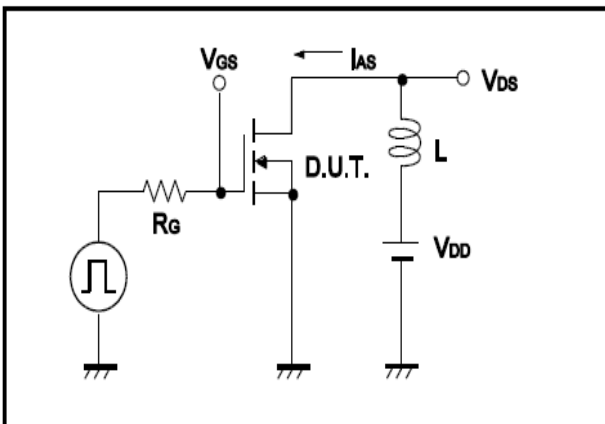
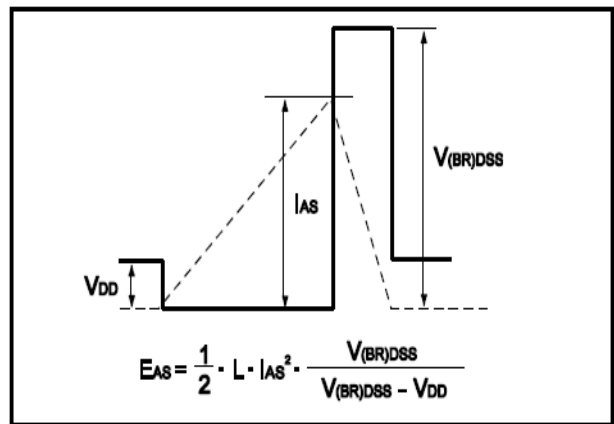

Fig.6 Avalanche Waveform



●Dimensions(SOP8)

Unit: mm

SYMBOL	min	TYP	max	SYMBOL	min		max
A	4.80		5.00	C	1.30		1.50
A1	0.37		0.47	C1	0.55		0.75
A2		1.27		C2	0.55		0.65
A3		0.41		C3	0.05		0.20
B	5.80		6.20	C4	0.19	0.20	0.23
B1	3.80		4.00	D		1.05	
B2		5.00		D1	0.40		0.62

